

STR-D550Z/D650Z/DE605/DE705

SERVICE MANUAL

US Model
STR-D550Z/D650Z/DE605/DE705

Canadian Model
STR-D650Z/DE605/DE705

Australian Model

E Model
STR-DE705



Photo : STR-DE705

Manufactured under license from Dolby Laboratories Licensing Corporation.
"DOLBY" and the double-D symbol  are trademarks of Dolby Laboratories Licensing Corporation.

SPECIFICATIONS

Audio power specifications

POWER OUTPUT AND TOTAL HARMONIC DISTORTION

With 8-ohm load, both channels driven, from 20 - 20,000 Hz, STR-DE705/STR-D650Z rated 120 watts, STR-DE605/STR-D550Z rated 100 watts per channel, minimum RMS power, with no more than 0.3 % total harmonic distortion from 250 milliwatts to rated output. (US model only)

Amplifier section

POWER OUTPUT

Stereo mode 8 ohms 20 Hz - 20 kHz,
STR-DE705/STR-D650Z:
120 W + 120 W
STR-DE605/STR-D550Z:
100 W + 100 W

Surround mode	8 ohms at 1 kHz, THD 0.8 %	
	STR-DE705 STR-D650Z	STR-DE605 STR-D550Z
Front	120 W/ch	100 W/ch
Center (only in the DOLBY SUR and THEATER modes)	120 W	100 W
Rear	50 W/ch	50 W/ch
Dynamic power output	STR-DE705/STR-D650Z: 160 W + 160 W, 8 ohms 225 W + 225 W, 4 ohms STR-DE605/STR-D550Z: 155 W + 155 W, 8 ohms 220 W + 220 W, 4 ohms	
Harmonic distortion at rated output	Less than 0.3 %	

Frequency response

PHONO: RIAA equalization curve
 ± 0.5 dB
CD, TAPE, DAT/MD, VIDEO 1, 2:
10 Hz - 50 kHz, ± 0.1 dB

Inputs

	Sensitivity	Impedance	S/N (weighting network, input level)
PHONO (MM)	2.5 mV	50 kilohms (A, 2.5 mV)	75 dB**
CD	200 mV		
TAPE, DAT/MD, VIDEO 1, 2, TV	150 mV	50 kilohms (A, 250 mV)	82 dB**

** '78 IHF

— Continued on page 2 —

FM STEREO/FM-AM RECEIVER
SONY®

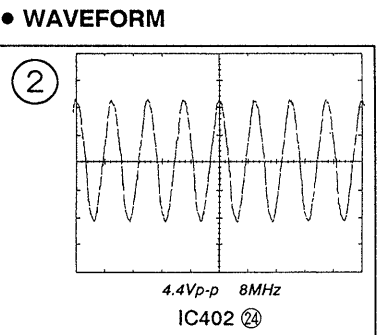
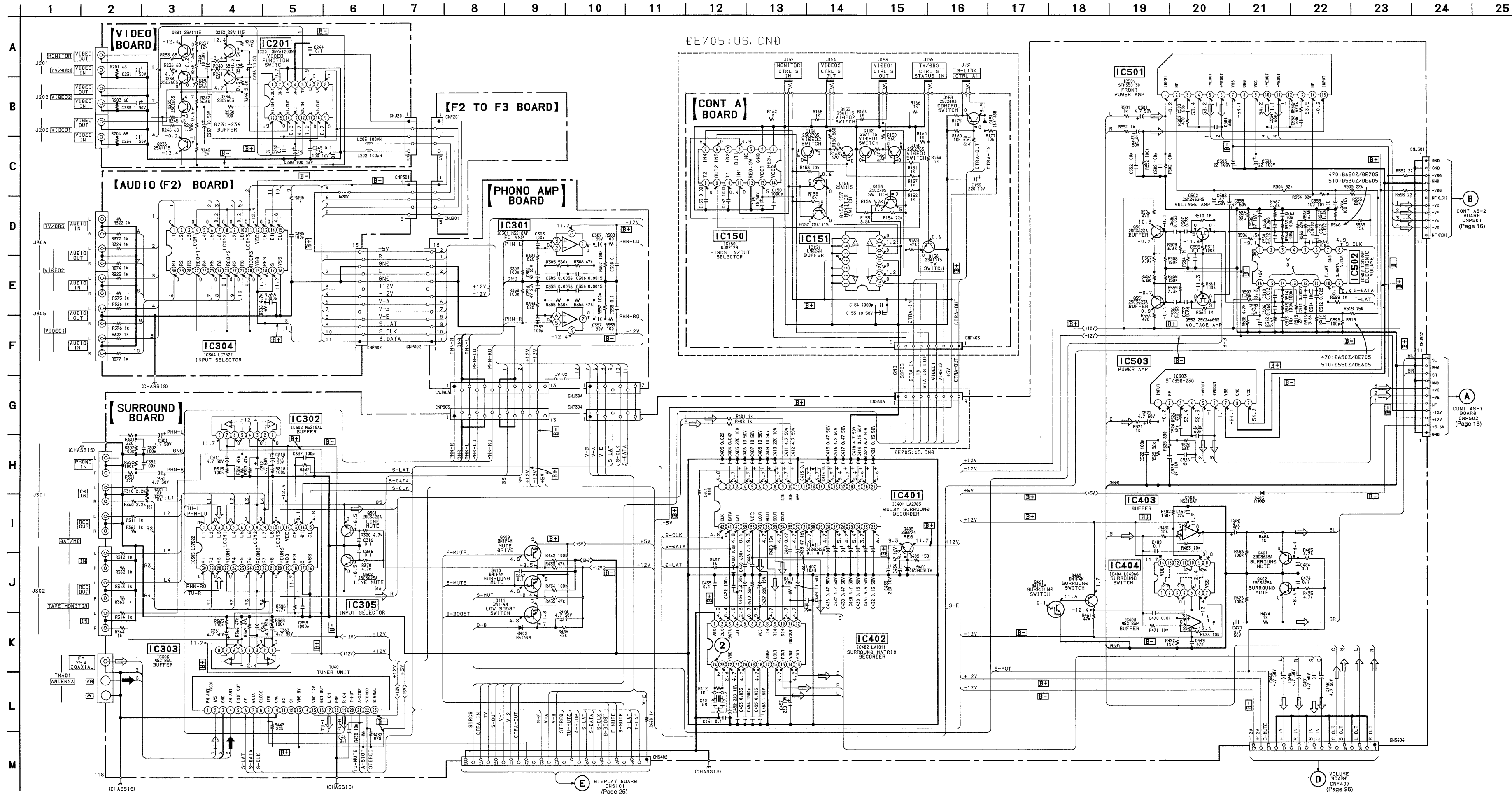

- Note :
- All capacitors are in μ F unless otherwise noted. pF: μ F
 - 50WV or less are not indicated except for electrolytics and tantalums.
 - All resistors are in Ω and $\frac{1}{4}W$ or less unless otherwise specified.
 - Δ : internal component.
 - \square : panel designation.
 - B+** : B+ Line
 - B-** : B- Line
 - Voltage and waveforms are dc with respect to ground under no-signal conditions.
 - no mark : TUNER
 - Voltages are taken with a VOM (Input impedance 10M Ω). Voltage variations may be noted due to normal production tolerances.
 - Waveforms are taken with an oscilloscope. Voltage variations may be noted due to normal production tolerances.
 - Circled numbers refer to waveforms.
 - Signal path.
 - \rightarrow : FM
 - \rightarrow : AM
 - For detailed E model of refer to US model.
 - Abbreviation
CND : Canadian
AUS : Australian

3-4. SCHEMATIC DIAGRAM (AMP SECTION)

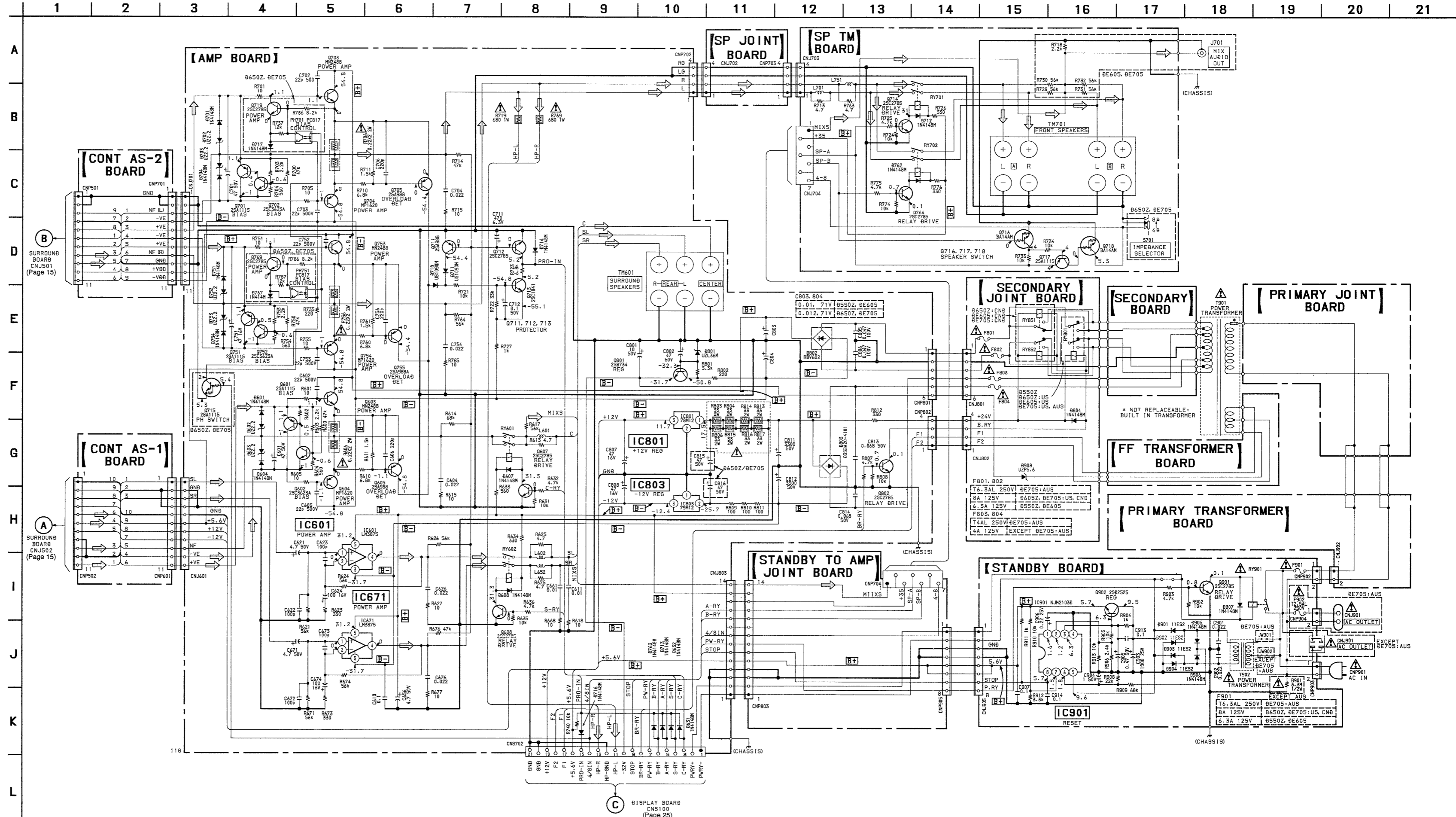

• IC BLOCK DIAGRAM – AMP SECTION –

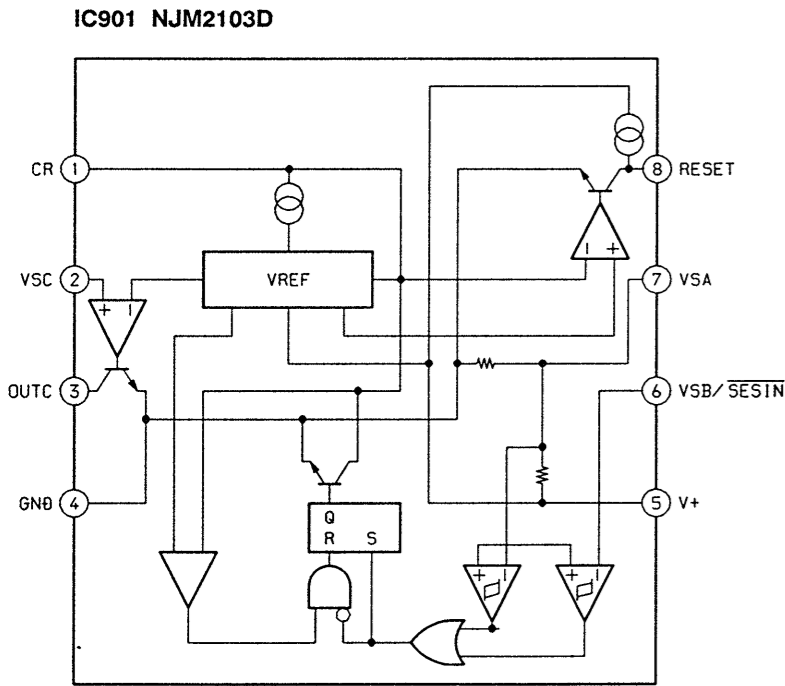

Note :

- All capacitors are in μF unless otherwise noted. pF : μF 50WV or less are not indicated except for electrolytics and tantalums.
- All resistors are in Ω and $\frac{1}{4}W$ or less unless otherwise specified.
- \square : nonflammable resistor.
- \square : panel designation.

Note :
The components identified by mark Δ or dotted line with mark Δ are critical for safety. Replace only with part number specified.

Note :
Les composants identifiés par une marque Δ sont critiques pour la sécurité. Ne les remplacer que par une pièce portant le numéro spécifié.

- $B+$: B+ Line
- $B-$: B- Line
- Voltage and waveforms are dc with respect to ground under no-signal conditions. no mark : TUNER
- Voltages are taken with a VOM (Input impedance 10M Ω). Voltage variations may be noted due to normal production tolerances.
- Signal path.
- \Rightarrow : FM
- For detailed E model of refer to US model.
- Abbreviation
CND : Canadian
AUS : Australian

• IC BLOCK DIAGRAMS – DISPLAY SECTION –

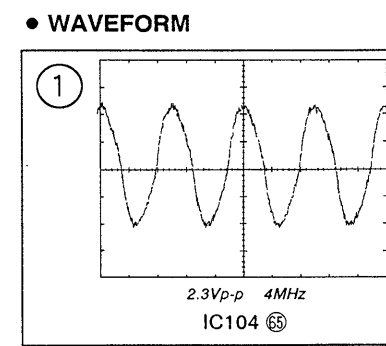
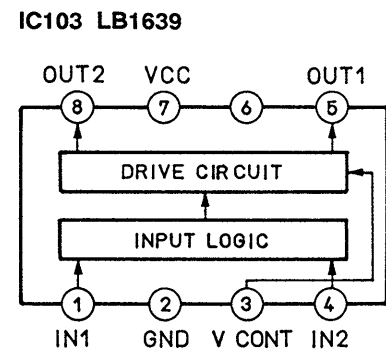
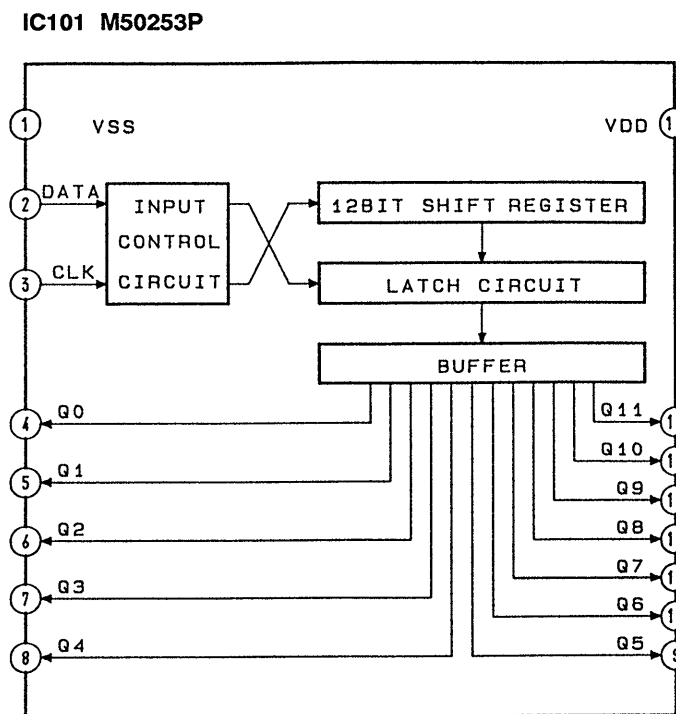
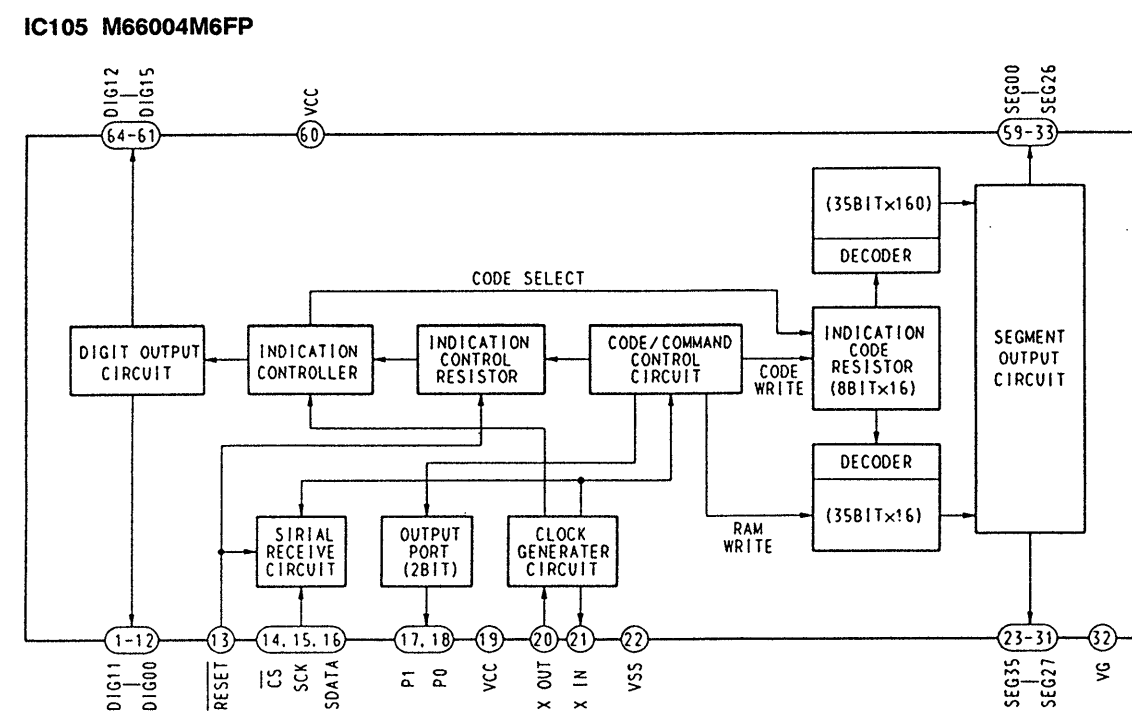

Note :

- All capacitors are in μ F unless otherwise noted. pF; μ μ F 50WV or less are not indicated except for electrolytics and tantalums.
- All resistors are in Ω and $\frac{1}{2}$ W or less unless otherwise specified.
- Δ : internal component.
- \square : panel designation.
- B+** : B+ Line
- B-** : B - Line
- Voltage and waveforms are dc with respect to ground under no-signal conditions.
- no mark : TUNER
- * : can not be measured
- Voltages are taken with a VOM (Input impedance 10M Ω). Voltage variations may be noted due to normal production tolerances.
- Waveforms are taken with an oscilloscope. Voltage variations may be noted due to normal production tolerances.
- Circled numbers refer to waveforms.
- Signal path.
- \Rightarrow : FM
- Abbreviation
- AUS : Australian

3-6. SCHEMATIC DIAGRAM (DISPLAY SECTION)

